

"AUTO-CAL" CAPACITANCE-TYPE MICRO-CONTROLLER FUEL LEVEL SENDER



WITH 2 OR 3 TERMINALS - ATL NUMBERS **KS220 & KS222**
USED WITH 240 TO 33 OHM GAUGES ONLY

Aero Tec Laboratories' microcontroller-based capacitance "senders" can be distinguished from our older analog style by an "A" in the current part number ex: AFLS, and no trim-adjust potentiometers on the top of the sender. Senders with aluminum tubing are for oil, diesel, or gasoline of up to 10% ethanol.

HOW THE SENDERS MEASURE LIQUID LEVEL:

These "senders" work by measuring capacitance without any moving parts. Electronics in the head convert this measured capacitance to the programmed output of ohms or volts. In fuel senders, capacitance is measured between the inner sensing tube and the grounded outer tube, and the fluid (fuel) must be non-conductive.

CAUTION: DISCONNECT THE BATTERY BEFORE MAKING ANY ELECTRICAL CONNECTIONS!

SHORTENING SENDERS (See Page 3)

"BENDING" SENDERS:

Do **NOT** Bend. A sender can be special-ordered if it needs to be bent to fit an odd shaped tank.

CONNECTIONS FOR 2-TERMINAL SENDER **KS220**

USE KS220 IF ELECTRIC POWER COMES FROM GAUGE

NEG: Connect this terminal to the battery ground (-). **NOTE:** Our senders work with negative-ground systems only.

SEND: Connect this to the input terminal (signal) of your gauge or display. **NOTE:** The signal is an electronic output which will confuse your ohmmeter if you try to take a resistance reading between the sender and ground. The 2-terminal sender works only with **+12V DC or +24V DC systems**.

SEE SYSTEM WIRING DIAGRAM ON PAGE 3

CONNECTIONS FOR 3-TERMINAL SENDER **KS222**

USE KS222 IF ELECTRIC POWER COMES FROM IGNITION SWITCH

POS: Connect this terminal to **+12 volt DC source only**.

NEG: Connect this terminal to the battery ground (-). **NOTE:** Our senders work with negative-ground systems only.

SEND: Connect this terminal to the input (signal) terminal (green wire, pg 2) of your gauge or display. **NOTE:** The signal is an electronic output which will confuse your ohmmeter if you try to take a resistance reading between the sender and ground. **SEE SYSTEM WIRING DIAGRAM ON PAGE 6**

"A"

End Cap

"SENDER"

KS220
2-TERMINAL SENDER

(Power from Gauge)

End Cap

"SENDER"

KS222
3-TERMINAL SENDER

(Power from Ignition Switch)

AUTO-CAL CAPACITANCE-TYPE MICRO-CONTROLLER FUEL LEVEL SENDER (CONT.)



WITH 2 OR 3 TERMINALS
ATL NUMBERS **KS220 & KS222**

CALIBRATION:

The output range (eg Empty 240 / Full 33 ohms) and alarm levels (if ordered) are set at the factory. They can be changed for you back at the factory if needed.

FACTORY CALIBRATIONS:

If you did not need to shorten the sender, the factory Empty and Full settings should be correct. Please contact us for advice if they seem wrong, rather than recalibrating.

Cut out foam baffling as shown on page 6 to allow sender insertion.



KS220
2-TERMINAL SENDER
(Power from Gauge)



KS222
3-TERMINAL SENDER
(Power from Ignition Switch)

AUTO-CAL CALIBRATIONS **KS220 & KS222**

Empty: After shortening the sender (if needed) and with sender out of the tank, connect the sender to the system wiring (see page 6) and turn on the power. The gauge needle should swing between Empty and Full a couple of times and return to Empty as the sender discovers its shorter length.

Full: Turn OFF the power and install the sender into a full tank (or vessel of equal depth) of the appropriate fuel. Turn ON the power. The reading should go above "Full" and then finish on "Full". This Autocal feature will reset "full" after each fill up. See pages 4 or 5 for trouble-shooting hints.

Note: For the "Full" Detection feature to work properly, sender must be installed in a full tank or equal-depth test rig, otherwise only an estimated fuel level will be displayed on the gauge until the tank is filled completely.

Note: MANUAL CALIBRATION for senders NOT stamped Auto-Cal - Please see pages 3-5

ATL **KS-208** FUEL LEVEL GAUGE KIT

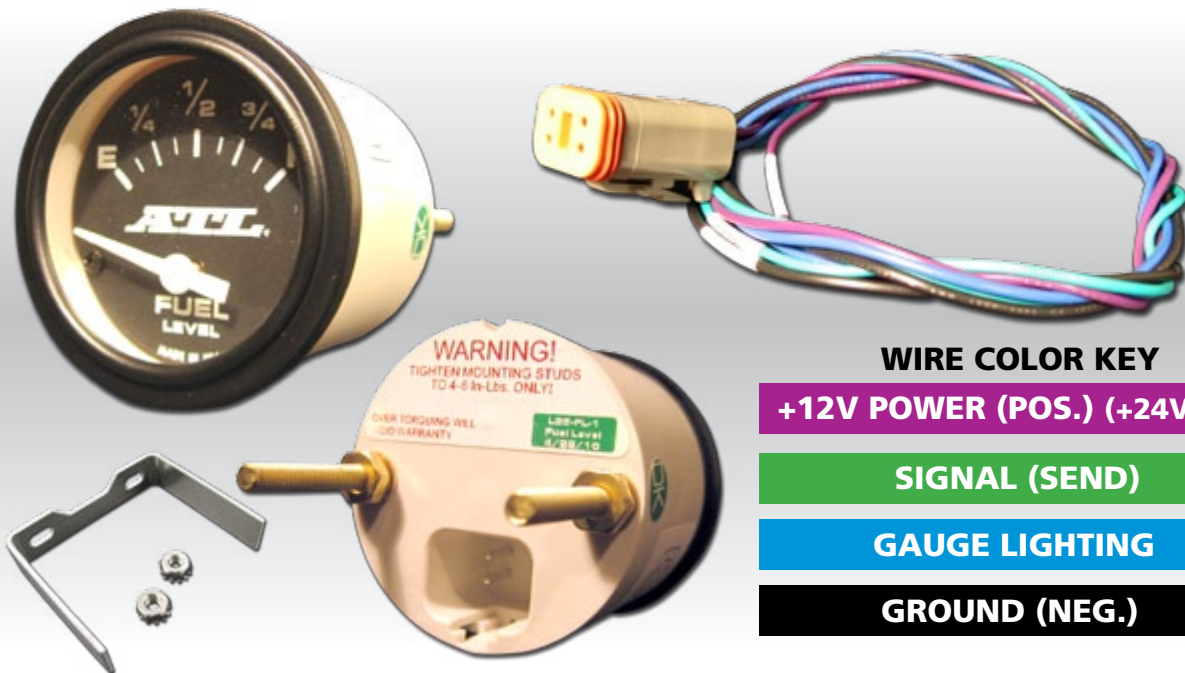

WIRE COLOR KEY

+12V POWER (POS.) (+24V OPT.)

SIGNAL (SEND)

GAUGE LIGHTING

GROUND (NEG.)

SEE SYSTEM WIRING DIAGRAM ON PAGE 6



FUEL LEVEL SENDER WITH TRIM/ADJUST POTENTIOMETERS (POTS)

INSTALLATION INSTRUCTIONS

WITH 2 OR 3 TERMINALS - ATL #s **KS225, 226, 228, 229, 230**
USED WITH GAUGES **OTHER THAN 240 TO 33 OHMS** & WITH
ALTERNATE OUTPUT VOLTAGES

SHORTENING LENGTH OF FUEL SENDER:

1. Measure the depth of your tank from the outside top to the inside tank bottom.
2. Using a tubing cutter cut the outside tube approximately 1/2 inch shorter than the measured tank depth. Be careful not to damage the inner tube.
3. Insulators are placed on the inner tube to prevent it from touching the outside tube. Slide the exposed insulators on the inner tube up until they are just inside the outer tube.
4. Using wire cutters, cut off the inner tube flush with the outer tube. Be sure the two tubes are not touching. The gauge will stay pegged above the Full mark when the ignition is turned on if they are touching.
5. Replace end cap as shown on page 1.

NOTE: Do not worry if the inner tube closes when cut - It will not affect the reading.

WARNING: 12" Senders can be cut to 6". 24" Senders can be cut to 13".
36" Senders can be cut to 25". 48" Senders can be cut to 37".

CALIBRATION OF FUEL SENDERS **KS225, 226, 228, 229, 230**

1. Your sender is calibrated at the factory prior to shipment - re-calibration will be required if you have to cut your sender; otherwise a minor adjustment of the FULL pot (potentiometer) is all that may be required.
2. Be sure the sender is dry before you attempt to calibrate. Residual liquid left inside the tube will give an erroneous reading and affect the calibration. If your sender has been immersed in liquid, let it dry for two hours before you calibrate. The EMPTY and FULL adjustment pots are located on top of the unit. A small phillips screwdriver is required to make the adjustment.
3. Do NOT install sender in tank at this point.

CAUTION: DISCONNECT THE BATTERY BEFORE MAKING ANY ELECTRICAL CONNECTIONS!

4. Make the wiring connections as shown on the wiring diagram (page 6).
5. With sender out of tank and all wires properly connected, you can start calibration.

- A. Relieve foam as shown on page 6 to accommodate sender.
- B. Turn the FULL and EMPTY screws to the full clockwise position. Do not force the screws.
- C. Slowly turn the "empty" pot counter-clockwise until the needle on the gauge just stops moving downward (the needle should be just below the EMPTY mark).
- D. Now turn the "empty" pot clockwise to make sure the needle starts moving upscale immediately. THIS IS YOUR EMPTY SETTING.
- E. Now install the sender in the tank and FILL TANK WITH FUEL. Alternatively, you can use a small container of tank depth.
- F. Turn the "FULL" pot counter clockwise until the needle is on the FULL mark not past it. Do not "PEG" the gauge.
- G. To check calibration remove SENDER from tank and allow to dry - once dry, gauge should read at EMPTY.



KS225
**2-TERMINAL
SENDER WITH
POTENTIOMETERS**
(Power from Gauge)



KS226, 228, 229, 230
**3-TERMINAL
SENDERS WITH
POTENTIOMETERS**
(Power from
Ignition Switch)

FUEL LEVEL SENDER - 2 TERMINAL WITH TRIM/ADJUST POTENTIOMETERS

2 TERMINALS - ATL NUMBER **KS225**

INSTALLATION: 2-WIRE SENDER WITH "POTS"

USE KS225 IF ELECTRIC POWER COMES FROM GAUGE AND RESISTANCE RANGE IS OTHER THAN 240 TO 33 OHMS

Place the gasket on the sending unit as below. Place the sender in the tank. Note the holes are not symmetrical, rotate until all the holes line up, then tighten down the 5 mounting screws.

WIRING: 2-WIRE SENDER

Wiring: It is recommended that number 16 AWG wire and crimp eyelet type terminals with insulated shanks be used to wire the sender unit to avoid the possibility of shorting the terminals. Secure all wire terminations with nuts and lock washers provided. **SEE SYSTEM WIRING DIAGRAM ON PAGE 6**

CAUTION: DISCONNECT THE BATTERY BEFORE MAKING ANY ELECTRICAL CONNECTIONS!

1. If you need to shorten sender length, see instructions on page 3.
2. Connect a wire from the SEND terminal on the sender to the SEND terminal on the meter.
3. Connect a wire from the NEG terminal on the sender to the NEG or GND terminal on the meter and to the battery ground (Neg. 12 volt terminal).
4. Cut out foam and calibrate per instructions on pages 3 & 6.
5. Connect the battery and turn on the ignition switch, the meter will go to the FULL mark then drop back to indicate the correct fuel level.
6. This completes the installation. Put a generous coating of sealant over the now-connected wire terminals and potentiometers.

TROUBLE SHOOTING HINTS:

SYMPTOM: Meter pointer stays above FULL mark when the Ignition switch is turned on.

- 1) Water in fuel tank.
- 2) SEND and NEG wires reversed on Sender Unit.
- 3) Meter not grounded properly.
- 4) SEND wire is touching NEG terminal or wiring
- 5) Center tube on fuel units touching the outer tube.
- 6) Sender not calibrated properly.

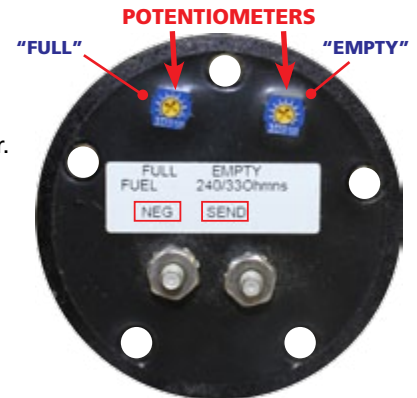

KS225
**2-TERMINAL
SENDER WITH
POTENTIOMETERS**
(Power from Gauge)

MOUNTING DIAGRAM
STANDARD 5-HOLE BOLT PATTERN

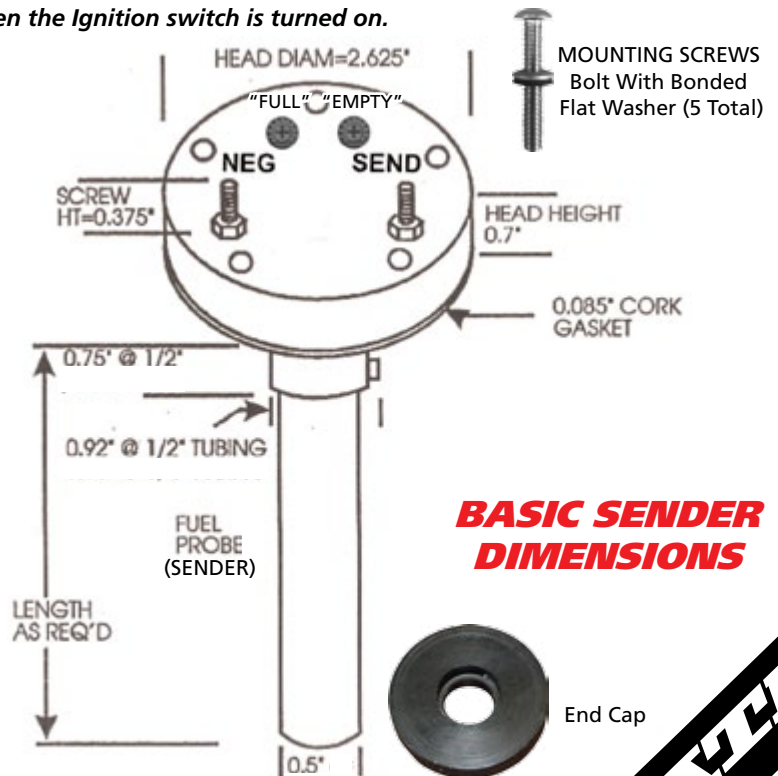
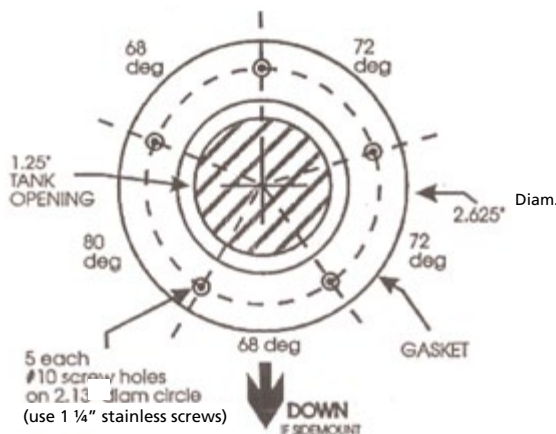

**BASIC SENDER
DIMENSIONS**

FUEL LEVEL SENDER - 3 TERMINAL WITH TRIM/ADJUST POTENTIOMETERS

WITH 3 TERMINALS - ATL NUMBER **KS226, 228, 229, 230**

3-WIRE SENDER WITH POTS INSTALLATION:

USE KS226 IF ELECTRIC POWER COMES FROM IGNITION SWITCH AND RESISTANCE RANGE IS OTHER THAN 240 TO 33 OHMS

If you had to trim your sender then the EMPTY adjustment must be made prior to installation. (See calibration instructions). Place the gasket on the sender. Align the holes and insert the mounting screws with flat washers and lock washers. Place the sender in the tank. Note the holes are not symmetrical, rotate until all the holes line up, then tighten down the 5 mounting screws.

3-WIRE SENDER WIRING:

Wiring: It is recommended that number 16 AWG wire and crimp eyelet type terminals with insulated shanks be used to wire the sender to avoid the possibility of shorting the terminals. Secure all wire terminations with nuts and lock washers. **SEE SYSTEM WIRING DIAGRAM ON PAGE 6**

CAUTION: DISCONNECT THE BATTERY BEFORE MAKING ANY ELECTRICAL CONNECTIONS!

1. If you need to shorten sender length, see instructions on page 3.
2. Connect a wire from the SEND terminal on the sender to the SEND terminal on the meter.
3. Connect a wire from the POS terminal on the sender to the POS or IGN terminal on the meter or to the 12 volt (24 or 32 volt if specified) electrical system at some point after the ignition switch.
4. Connect a wire from the NEG terminal on the sender to the NEG or GND terminal on the meter and to the battery ground (Neg. 12 volt terminal).
5. Connect the battery and turn on the ignition switch, the meter will go to the FULL mark then drop back to indicate the correct fuel level.
6. This completes the installation. Put a generous coating of sealant over the wire terminals and the adjustment pots.

TROUBLE SHOOTING HINTS:

SYMPTOM: Meter pointer stays above FULL mark when the Ignition switch is turned on.

- 1) Water in fuel tank.
- 2) SEND and NEG wires reversed on Sending Unit.
- 3) Meter not grounded properly.
- 4) SEND wire is touching NEG terminal or wiring
- 5) Center rod on fuel units touching the outside tube.
- 6) Sender not calibrated properly.



KS226, 228, 229, 230

3-TERMINAL SENDER WITH POTENTIOMETERS

(Power from
Ignition Switch)

MOUNTING DIAGRAM STANDARD 5-HOLE BOLT PATTERN

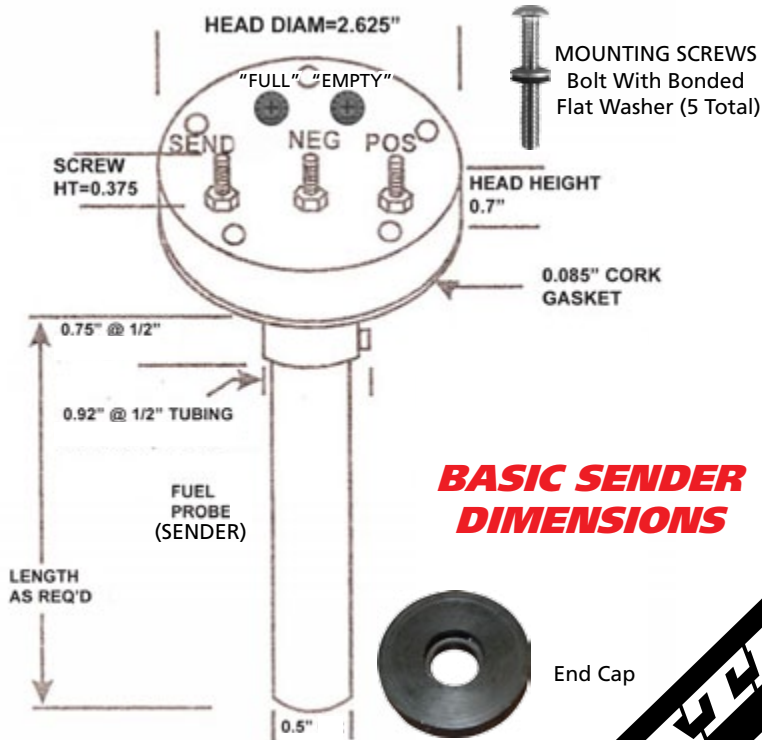
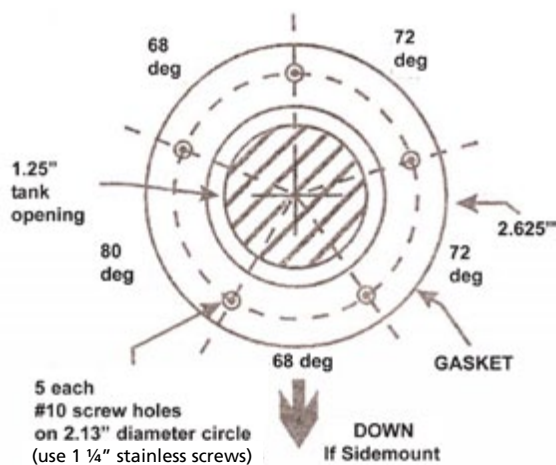

BASIC SENDER DIMENSIONS

ATL FUEL CELL LEVEL GAUGE KIT TYPICAL INSTALLATION DIAGRAM FOR CAPACITANCE-TYPE SENDERS

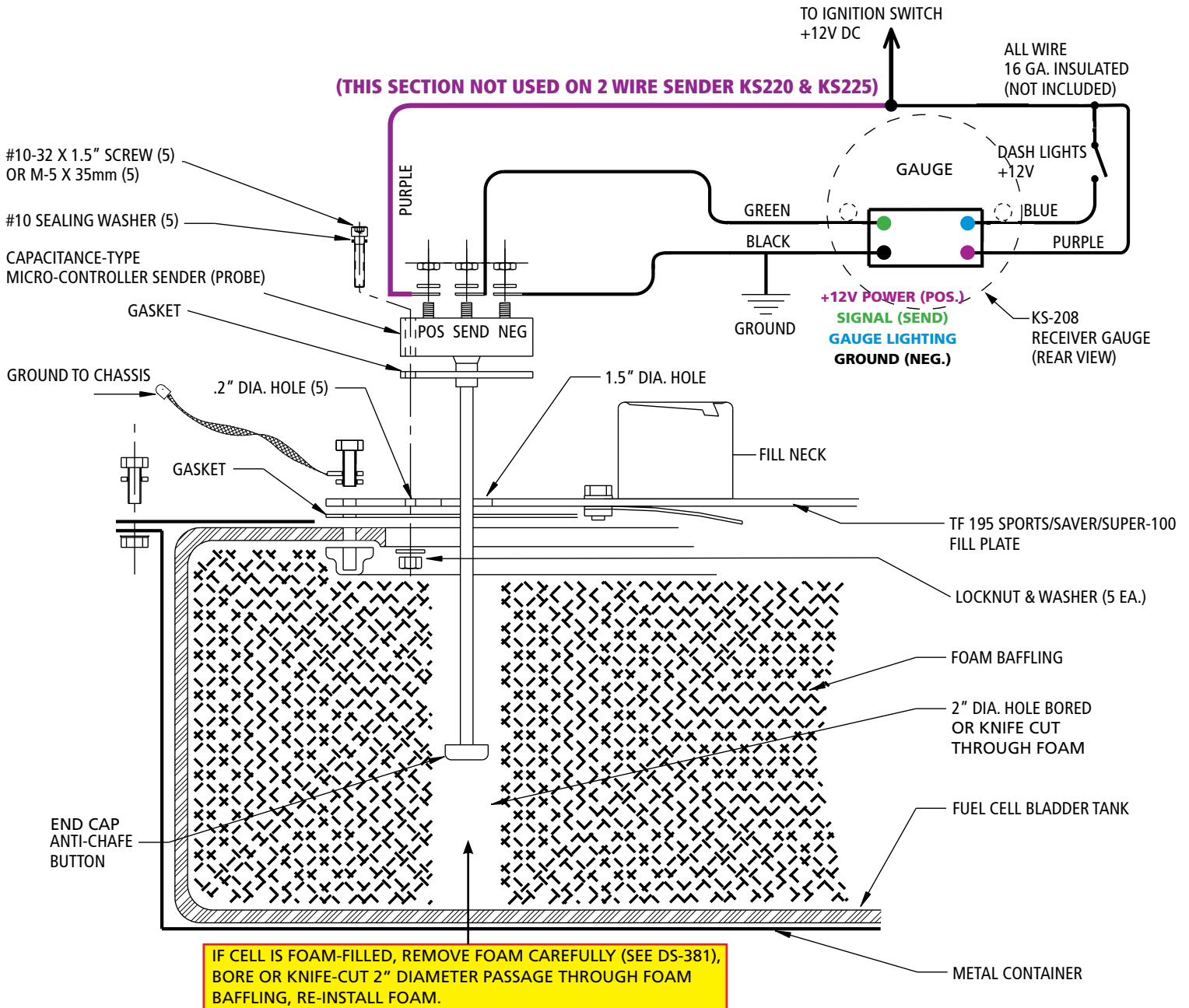

FOR USE WITH JET FUEL, DIESEL OR GASOLINE CONTAINING UP TO 10% ETHANOL

World Headquarters

Aero Tec Laboratories Inc.
45 Spear Road Corporate Park
Ramsey, New Jersey 07446-1251 USA
Tel: +1-201-825-1400 • Fax: +1-201-825-1962
Email: atl@atllinc.com • Web: atllinc.com

European Operations

Aero Tec Laboratories Ltd.
ATL Technology Centre, Denbigh Road
Bletchley, Milton Keynes, MK1 1DF
Tel: +44 (0) 1908-351700 • Fax: +44 (0) 1908-351750
Email: atl@atlltd.com • Web: atlltd.com